

POWERRAIL ENCLOSED CONDUCTOR SYSTEM

KBH



Contents	Page
System photo	2
General	2, 3
Types, technical data, order-numbers	4,5
Joining material, hangers, end caps	6
Brackets	7
End feeds, Line feeds	8, 9
Curves, Sealing strips	10
Heating systems	11
Contact Sections, Turntables and Switches	12
Transfer funnels, Transfer guides	13

Contents	Page
Removing sections, Conductor dead sections	14
Anti-condensation sections, Expansion sections	15
Single Collectors	16
Double Collectors, Tow Arms	17
Flexible tow arms, arrangement	18
Example for ordering, Spare parts	19,20
Questionnaire	21,22
Application photos	23
Product range	24

System photo

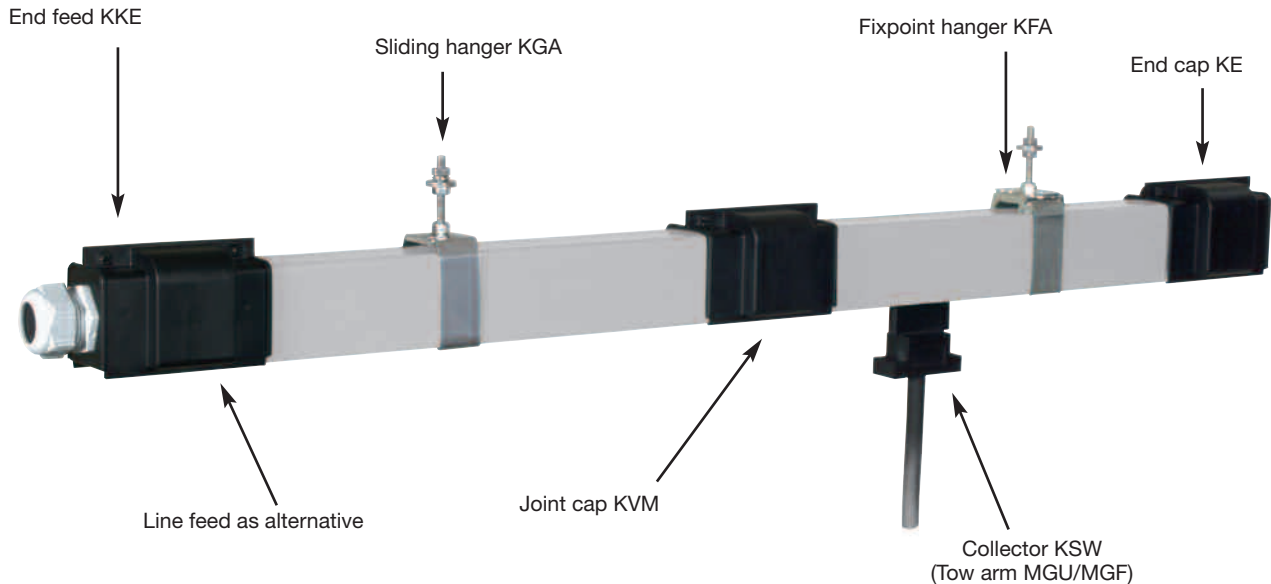

General

The Vahle-Powerail KBH is a shock hazard protected conductor system for indoor and outdoor installations.

The plastic housing can accommodate different copper profiles.

Type KBHF in 4- and 5-conductor version, with preassembled copper conductors and spring loaded connectors from 40 to 100 A.

Type KBHS in 4- and 5-conductor version, with preassembled copper conductors and bolted joints from 40 to 200 A.

A compact design, corrosion resistance and easy installation are the main characteristics.

The KBH complies with VDE, european and international standards as well as accident prevention regulations. It is protected to IP 23 standards.

The KBH can be supplied with sealing strip and heating system. The powerail with sealing strip is protected to IP 24 standards and EN 60529 (0470, port 1) regulation.

Collectors are proven against touch only when fully entered into the powerail.

If there is the possibility to touch live parts by hand, ie. collectors that might leave the powerail during operation, provide safety barrier or disconnect mains. This is valid only for a supply voltage exceeding 24 V AC or 60 VDC.

If a conductor is used as N please note VDE 0100 part 430. Format according to IP 44 available on request.



Applications

For mobile power consumers like cranes, monorails, electric hoists, machine tools, automated storage and retrieval systems, lighting systems.

Housing

Color gray, plastic housing for 4 or 5 conductors. Standard section 4 m. Other sections are available. The ground conductor is identified by international color code. Phase reversing prevented by design of the collector and housing. Higher number of conductors possible by combination of several powerails.

Couplings

Through plastic joint caps.

Feed Sets

Line feeds or end feeds.

End caps

The open ends of the powerail are closed by end caps for KBHF and KBHS.

Hangers

Standard brackets for powerail attachment to crane girders are available (see page 7). Powerail with sliding and fixpoint hangers. Maximum distance between suspension points for indoor and outdoor installations : 2000 mm.

Expansion during temperature fluctuation

The Expansion sections are required to compensate the different expansions between copper conductors and steel- or concrete structures, in varying temperatures without interrupting electrical power.

Expansion joints are used when the Powerail length between feeds, curves, switches or other fix points is exceeding 20 m.

Install one expansion joint every 100 m.

The different expansions between the plastic housing and the copper conductors will be compensated in every joint.

Anti-condensation sections

These sections are used for transfer of the Powerail to outdoor areas to avoid condensation. The Powerail is not separated electrically.

Contact sections, turntables and switches

Powerail for working areas and transfer applications see page 12 and 13.

Sectionalizing

Available as air gap version (5 mm), where the collector carbon bridges the gap, e. g. for mains. Also available as insulating piece version (35 mm). In this case the insulating piece is longer than the carbon and each Powerail section can be separated electrically, e.g. for control.

Collectors

The current collectors are made of re-inforced polyester fiberglass, for high strength and light weight. Spring loaded carbon brushes maintain uniform contact. Connecting cables and hinged or flexible towing arms included. Double collectors for transfer applications and higher amperage.

The length of the collector cable may not exceed 3 m if the added over-current protection device is not designed for the load capacity of this cable. Please refer also to regulations VDE 0100, part 430 and EN 60204-32.

(Note: this might happen in case of several collectors running in one system).

Removing section for Collectors

Assembly and disassembly of the collector is possible at the end of the track as well as at the removing section. By opening and closing the sliders at the bottom of the Powerail housing the collector can be mounted and demounted easily. Before opening the removing section the Powerail has to be without voltage.

Safety advice

It must be ensured that the arrangement of the conductor system provides minimum distances (0,5 m) between fixed and mobile plant parts (i.e. between conductor rails, collector trolleys and towing arms) so as to avoid the risk of pinching.

Please note: For use in galvanizing and pickling plants, under aggressive conditions and low voltage applications we would appreciate receiving detailed information, especially of the environmental conditions. For quotations and order processing including Powerail systems with curves, dead sections, turntables, switches etc. we require your drawings or sketches. Please use our questionnaire, page 21/22.

Technical data			
Powerail electrical values:		Mechanical properties:	
max. current	see page 4	Flexible strength	75 N/mm ² ± 10 %
max. voltage	600 V	Tensile strength	40 N/mm ² ± 10 %
Dielectric strength	DIN 53481		
	30-40 kV/mm	Temperature range (ambient):	- 30 °C up to + 60 °C
Spec. resistance	IEC 60093		
	5 x 10 ¹⁵ Ohm/cm		
Surface resistivity	IEC 60093		
	10 ¹³ Ohm		
Leakage resistance	IEC 112/VDE 0303		
	CTI 600-2,7		
Combustibility:		Resistance to chemicals:	
flame retardant	DIN 41 02 –	at + 45 °C	Gasoline
self extinguishing	part 1		Mineral Oil
			Grease
			Sulphuric acid 50 %
			Caustic soda 25 % & 50 %
			Hydro-chloric acid, concentrated

Consider the voltage drop calculation to maintain the limits established by the motor manufacturers!

Formulas:

AC: $\Delta U = \sqrt{3} \times I \times l \times Z$

DC: $\Delta U_1 = 2l \times I \times R$

$$\Delta U_2 = \frac{\Delta U_1 \cdot 100}{V}$$

Effective length:

- l = L power feed located at the end of the system
- l = L/2 power feed located at the center of the system
- l = L/4 power feed located at both ends of the system
- l = L/6 power feed located at L/6 from each end of the system

- ΔU_1 = Voltage drop [A]
- ΔU_2 = Voltage drop [%]
- I = Ampere load [A]
- R = Resistance [Ohm/1000 m]
- l = Power feed length [m]
- L = System length [m]
- Z = Impedance [Ohm/1000 m]
- V = Voltage rating [V]

The total ampere load is determined from the nominal rated current of all motors working simultaneously on the same feed section of your electrification system. A diversity factor of 0,5-0,9 can be considered.

The conductor size and/or number of feed points should be increased or booster cables should be used in parallel in case the drop is exceeding the limitations.



TYPES • TECHNICAL DATA • ORDER NUMBERS

KBHF with spring loaded connectors

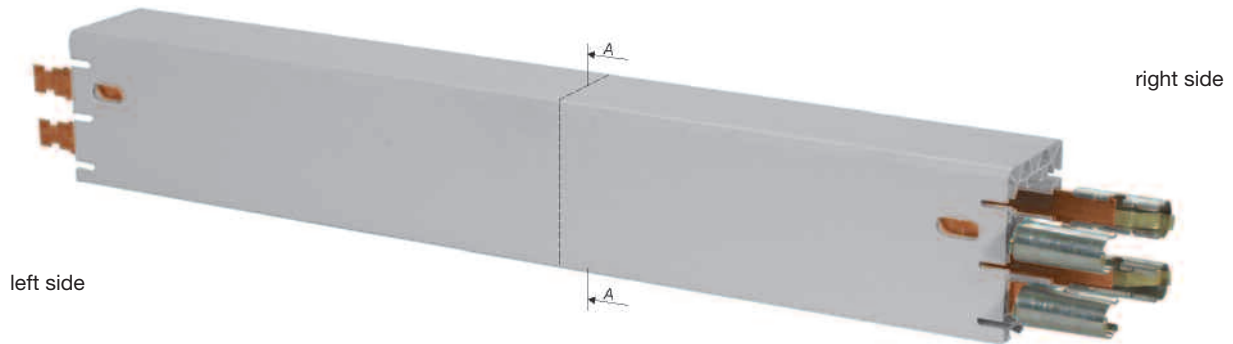

KBHF

Type ⁽¹⁾	HS with PE SS without PE	No. of conductors	Max. continuous current A at 35 °C			conductor cross section mm ²				control-line	max. Voltage V
			60% DF	80% DF	100% DF	L1 L2 L3		N/5 ⁽²⁾			
KBHF 4/ 40...HS		4	52	45	40	3x10	10	-		600	
KBHF 4/ 40...SS	control line	4	52	45	40	-	-	-	4x10	600	
KBHF 4/ 63...HS		4	81	70	63	3x14	14	-		600	
KBHF 4/100...HS		4	129	112	100	3x26	26	-		600	
KBHF 5/ 40...HS		5	52	45	40	3x10	10	10		600	
KBHF 5/ 40...SS	control line	5	52	45	40	-	-	-	5x10	600	
KBHF 5/ 63...HS		5	81	70	63	3x14	14	14		600	
KBHF 5/100...HS		5	129	112	100	3x26	26	26 ⁽³⁾		600	
KBHS 4/ 40...HS		4	52	45	40	3x10	10	-		600	
KBHS 4/ 40...SS	control line	4	52	45	40	-	-	-	4x10	600	
KBHS 4/ 63...HS		4	81	70	63	3x14	14	-		600	
KBHS 4/100...HS		4	129	112	100	3x26	26	-		600	
KBHS 4/125...HS		4	161	140	125	3x33	26	-	-	600	
KBHS 4/160...HS		4	207	179	160	3x51	26	-		600	
KBHS 4/200...HS		4	258	224	200	3x70	42	-		600	
KBHS 5/ 40...HS		5	52	45	40	3x10	10	10		600	
KBHS 5/ 40...SS	control line	5	52	45	40	-	-	-	5x10	600	
KBHS 5/ 63...HS		5	81	70	63	3x14	14	14	-	600	
KBHS 5/100...HS		5	129	112	100	3x26	26	26 ⁽³⁾	-	600	
KBHS 5/125...HS		5	161	140	125	3x33	26	26 ⁽³⁾	-	600	
KBHS 5/160...HS		5	207	179	160	3x51	26	26 ⁽³⁾	-	600	
KBHS 5/200...HS		5	258	224	200	3x70	42	26 ⁽³⁾	-	600	

⁽¹⁾...Suffix types e.g. 2 m KBHF 4/63 with PE → KBHF 4/63 - 2 HS Order-No. 600 012, shorter lengths are made up from the next larger standard length.

⁽²⁾ In case of using a conductor as N see page 2.

⁽³⁾ 5th. Conductor max. 80 A at 100% DF.

KBHS with bolted joints

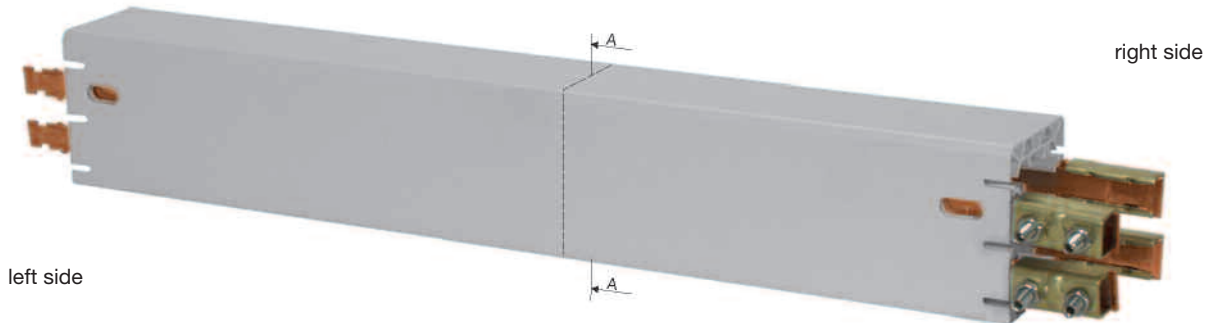

Leakage-distance mm	Impedance at 50 HZ and 20 °C $\Omega / 1000 \text{ m}$	Resistance at 20 °C $\Omega / 1000 \text{ m}$	Weight kg/m	Order-No. ⁽¹⁾
33	1,724	1,717	1,351	600 00•
33	1,724	1,717	1,351	600 03•
33	1,258	1,249	1,487	600 01•
33	0,702	0,687	1,903	600 02•
33	1,724	1,717	1,452	600 10•
33	1,724	1,717	1,452	600 13•
33	1,258	1,249	1,622	600 11•
33	0,702	0,678	2,142	600 12•
33	1,724	1,717	1,481	600 04•
33	1,724	1,717	1,481	600 09•
33	1,258	1,249	1,617	600 05•
33	0,702	0,687	2,033	600 06•
33	0,568	0,549	2,207	600 07•
30	0,376	0,351	2,699	600 08•
27	0,283	0,255	3,357	600 31•
33	1,724	1,717	1,614	600 14•
33	1,724	1,717	1,614	600 19•
33	1,258	1,249	1,784	600 15•
33	0,702	0,687	2,304	600 16•
33	0,568	0,549	2,479	600 17•
30	0,376	0,351	2,970	600 18•
27	0,283	0,255	3,628	600 32•

A - A
KBH 4-conductors

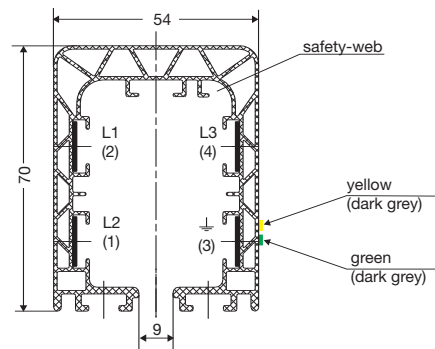

A - A
KBH 5-conductors

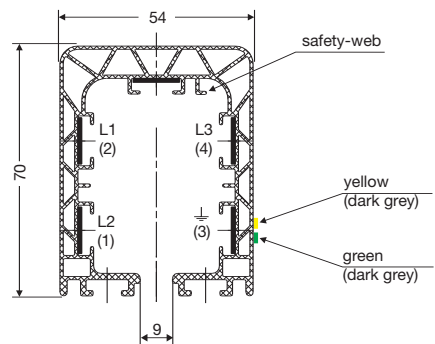

Designation in brackets are valid if used as control line.

KBHF

KBHS

• The last number of the order specifies the section length.
Please suffix the order number with 1, 2, 3, 4.

⊕ Ground= PE



JOINTING MATERIAL • HANGERS • END CAPS

KBHF
KBHS

Joint cap, self locking

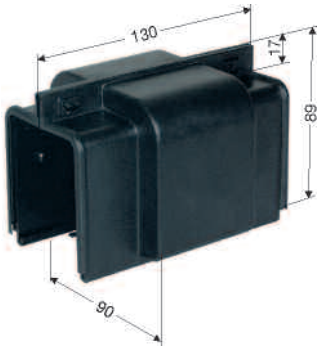

ready installed

Type	weight kg	Order-No.
KVM	0,096	600 005

Sliding hanger



Sliding hanger at powerail section

Type ⁽¹⁾	weight kg	Order-No.
KGA	0,100	600 000
KGA/K	0,100	600 397

Fixpoint hanger



Fixpoint hanger at powerail section

Typ ⁽¹⁾	weight kg	Order-No.
KFA	0,132	600 007
KFA/K	0,132	600 398

End cap, left and right version

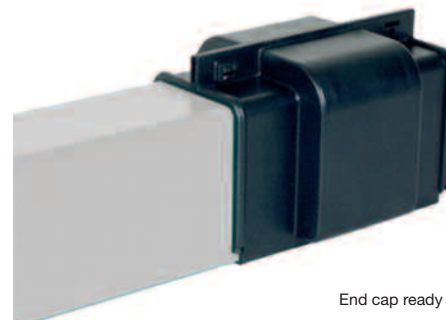
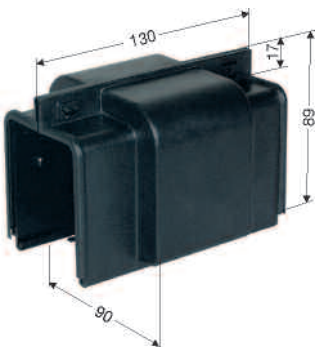

End cap ready installed

Type	weight kg	Order-No.
KE	0,120	600 008

view without I-beam

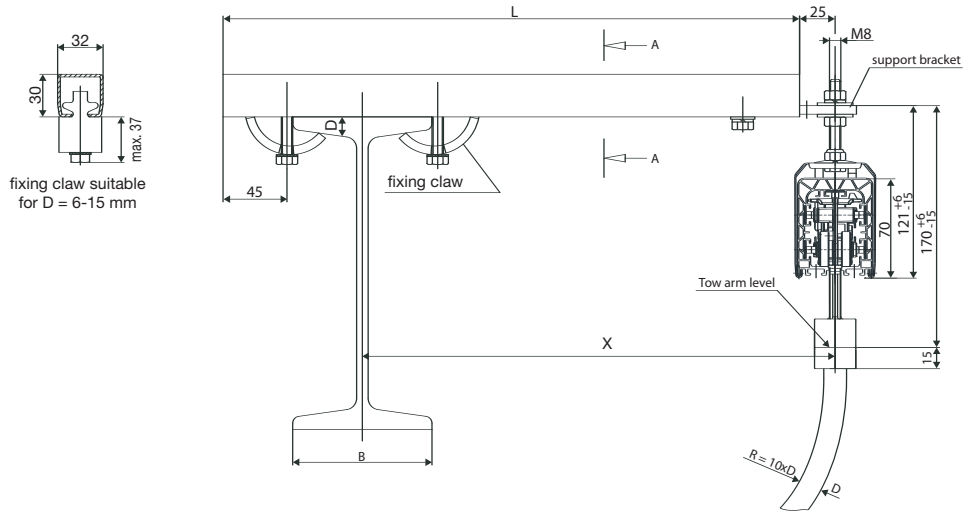

view without I-beam

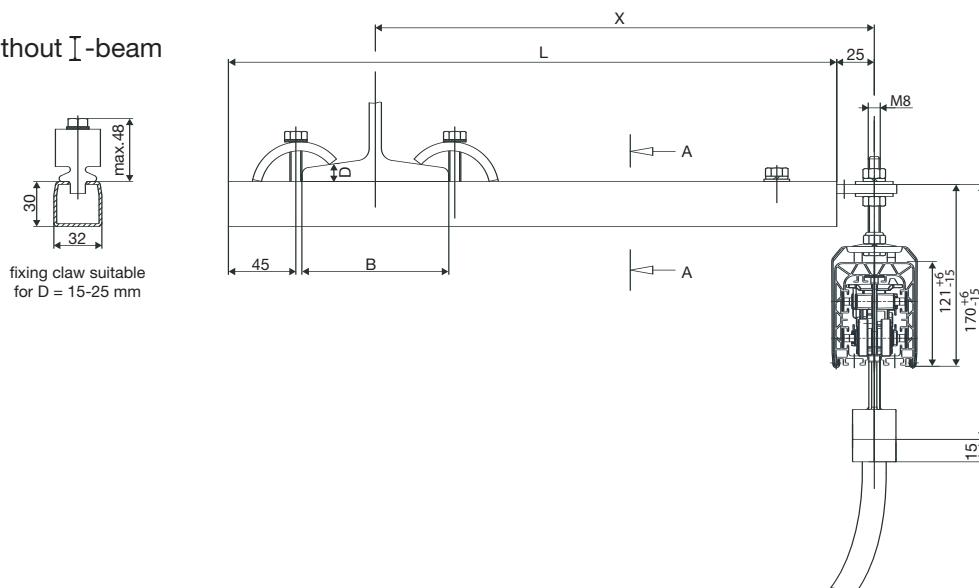

Arrangement EHK with small fixing claw

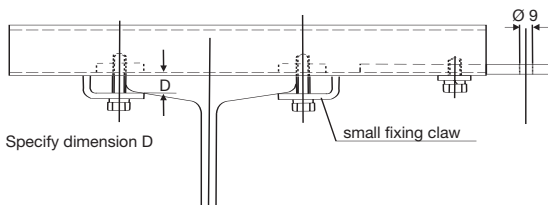

Attention!
Make sure that hoist wheels have enough clearance.
Use small claw if necessary. Check I-beam dimension D!

□ - rail of EHK is identical to type S 1, Cat. 8 a

Type	X mm	L mm	B max mm	weight kg	Order-No. standard-Version	Order-No. with small fixing claw
EHK 250	250	350	170	1,070	251 600	251 720
EHK 300	300	400	170	1,150	251 610	251 730
EHK 400	400	500	170	1,300	251 620	251 740
EHK 500	500	600	170	1,450	251 630	251 750
EHK 600	600	700	170	1,600	251 640	251 760
EHK 700	700	800	170	1,750	251 650	251 770
EHK 750	750	850	170	1,820	251 660	251 780
EHK 800	800	900	170	1,900	251 670	251 790

Select next larger size bracket when your I-beam dimension B is more than 170 mm.



END FEEDS • LINE FEEDS

KBHF
KBHS

End feeds

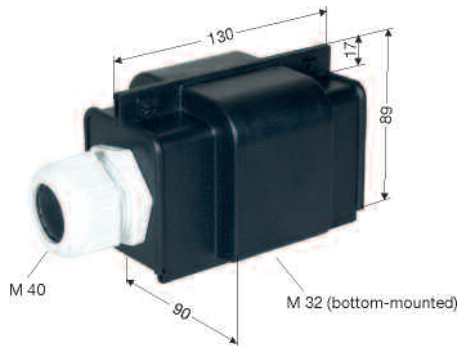

End feed comes loose without powerail section.
It can be mounted at the left or right hand side.

Electrical connection with customer supplied cable shoes to M 6 terminals.

Type	Cable gland (dimensions see S. 11)	Weight kg	Order-No.
KKE 4/40-63 HS	M 40	0,218	600 010
KKE 5/40-63 HS	M 40	0,230	600 107
KKE 4/40 SS	M 32	0,196	600 015
KKE 5/40 SS	M 32	0,208	600 108

Line feed (40 - 63 A)

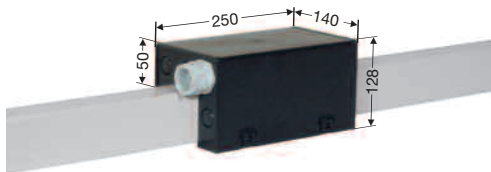

KSE type comes loose without powerail section.
It can be mounted at any joint.

Electrical connection with customer supplied cable shoes to M 6 terminals.

Type	cable gland (dimensions see S. 11)	weight kg	Order-No.
KSE 4/ 40 HS	M 25	0,756	600 030
KSE 4/ 63 HS	M 32	0,776	600 035
KSE 5/ 40 HS	M 25	0,812	600 037
KSE 5/ 63 HS	M 32	0,832	600 038
KSE 4/ 40 SS	M 25	0,756	600 028
KSE 5/ 40 SS	M 25	0,812	600 029

Line feed (100 A)

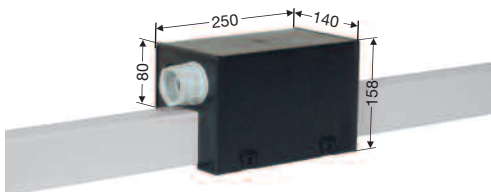

KSE type comes loose without powerail section.
It can be mounted at any joint.

Electrical connection with customer supplied cable shoes to M 6 terminals.

Type	cable gland (dimensions see S. 11)	weight kg	Order-No.
KSE 4/100 HS	M 50	0,908	600 036
KSE 5/100 HS	M 50	0,964	600 039

Line feed including 1 m section (40 - 100 A)

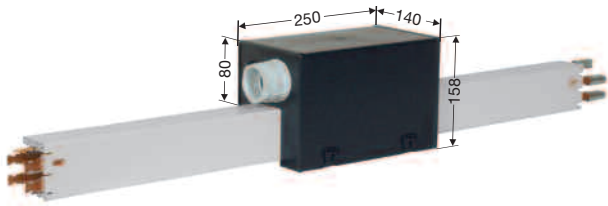

Line feed including 1 m section (125 A)

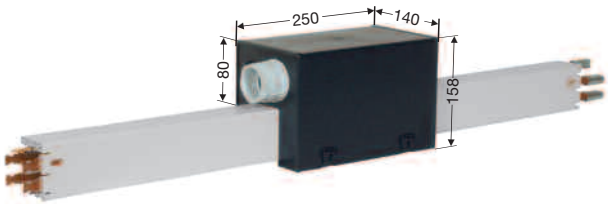

Line feed including 1 m section (40 - 63 A)

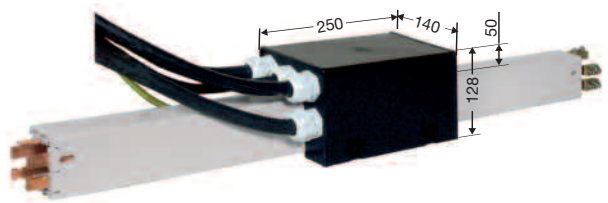

Terminal Box for KELS (125 -200 A)

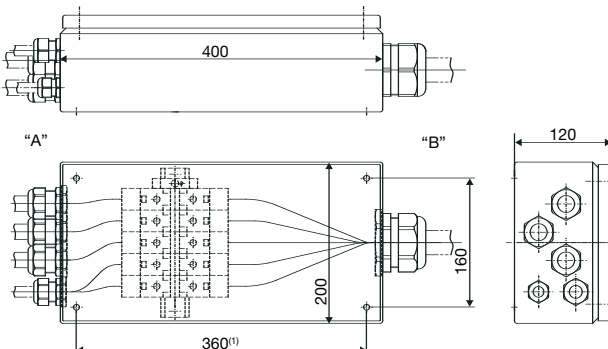

(1) Fixing borings \varnothing 7 mm at the bottom of the box.

Electrical connection with customer supplied cable shoes to M 6 terminals..

Type	Measure		Cable gland (dimensions see S.10)	weight kg	Order-No.
	a	b			
KEF 4/ 40 HS	50	128	M 25	2,099	600 197
KEF 4/ 63 HS	50	128	M 32	2,255	600 199
KEF 5/ 40 HS	50	128	M 25	2,256	600 205
KEF 5/ 63 HS	50	128	M 32	2,446	600 207
KEF 4/100 HS	80	158	M 50	2,803	600 201
KEF 5/100 HS	80	158	M 50	3,098	600 209
KEF 4/ 40 SS	50	128	M 25	2,099	600 195
KEF 5/ 40 SS	50	128	M 25	2,256	600 203

Electrical connection with customer supplied cable shoes to M 6 terminals.

Type	Measure		Cable gland (dimensions see S.10)	weight kg	Order-No.
	a	b			
KES 4/ 40 HS	50	128	M 25	2,229	600 221
KES 4/ 63 HS	50	128	M 32	2,385	600 223
KES 5/ 40 HS	50	128	M 25	2,413	600 229
KES 5/ 63 HS	50	128	M 32	2,608	600 231
KES 4/100 HS	80	158	M 50	2,933	600 225
KES 4/125 HS	80	158	M 50	3,251	600 045
KES 5/100 HS	80	158	M 50	3,260	600 233
KES 5/125 HS	80	158	M 50	3,606	600 049
KES 4/ 40 SS	50	128	M 25	2,229	600 219
KES 5/ 40 SS	50	128	M 25	2,418	600 227

Electrical connection with customer supplied cable shoes to M 6 terminals.

Type	Cable cross section in sqmm /Dia			weight kg	Order-No.
	L1-L3	Earth	Neutral		
KELS 4/125 HS	35/16	25/10	-	8,560	600 069
KELS 4/160 HS	50/18	25/10	-	9,784	600 075
KELS 4/200 HS	70/21	35/11	-	11,400	600 385
KELS 5/125 HS	35/16	25/10		9,372	600 077
KELS 5/160 HS	50/18	25/10	25/15	10,596	600 079
KELS 5/200 HS	70/21	35/11		12,212	600 387

Electrical connection with customer supplied cable shoes. Clamping range 16-95 sqmm.

View „A“ Input of the single cores of the KELS (a.m.)
View „B“ with M 63 (Dimensions see page 10)

Type	for line feed	weight kg	Order-No.
ZK 1	KELS 4/125 HS	5,030	600 389
ZK 2	KELS 4/160-200 HS	5,040	600 390
ZK 3	KELS 5/125 HS	5,370	600 391
ZK 4	KELS 5/160-200 HS	5,380	600 392

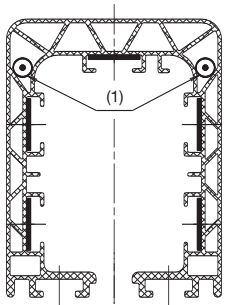

(1) Arrangement of heating cable

We recommend a heating system for outdoor installations and powerails in humid plants. The heating consists of arrangement two heating cables as per adjoining.

Attention: Switch on heating system below + 5 °C.

The type of heating cable has to be calculated: heat output per heating cable between **20 - 25 W/m**.

For bigger heating distances the total length has to be divided into different heating sections.

For smaller heating distances to feed with lower secondary voltage via transformer.

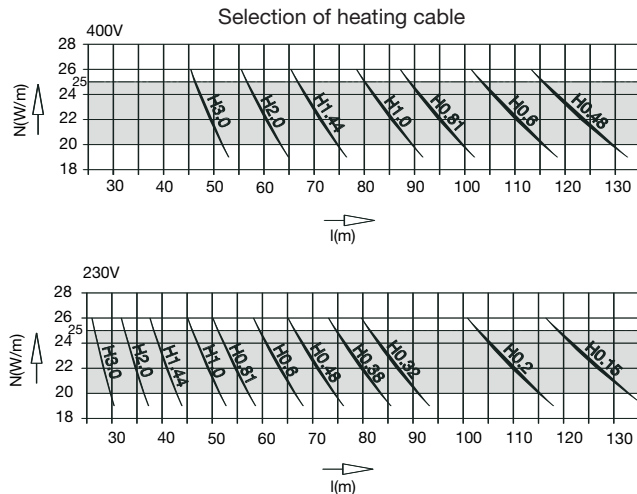

$$\text{Heating capacity [Watt/m]: } N' = \frac{U^2}{R \cdot L^2}$$

U = Supply voltage [Volt]
 R = Resistance of heating cable [Ohm/m]
 L = Length of heating section [m]

Wire resistance data:

- heating cable: H 0,15 → 0,15 Ohm/m
- heating cable: H 0,20 → 0,20 Ohm/m
- heating cable: H 0,32 → 0,32 Ohm/m
- heating cable: H 0,38 → 0,38 Ohm/m
- heating cable: H 0,48 → 0,48 Ohm/m
- heating cable: H 0,60 → 0,60 Ohm/m
- heating cable: H 0,81 → 0,81 Ohm/m
- heating cable: H 1,00 → 1,00 Ohm/m
- heating cable: H 1,44 → 1,44 Ohm/m
- heating cable: H 2,00 → 2,00 Ohm/m
- heating cable: H 3,00 → 3,00 Ohm/m

Deviations: ± 2,5 %

Installation of heating cable:

- Heating resistor made of CrNi (different conductors)
- Isolation of heating cable PTFE (Teflon)
- nickel-plated copper netting
- Sheath PTFE-Isolation

Outer diameter:

3,7 mm - 4,3 mm

Junction box for heating

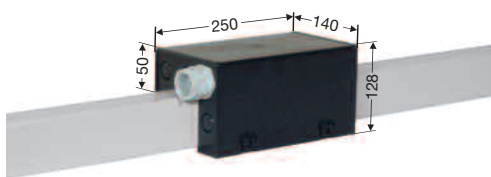

Type of Junction box	cable gland Measurements see page 9	Order-No.
left end	M 25	600 155
right end	M 25	600 156
line feed	2x M 25	600 065
1 set material for connecting clamps		195 291

For each end feed box 2 sets of material for connecting ends are required.

For line feed you need 4 sets of material for connection ends.

Wiring layout for a heating section with junction boxes at each end.

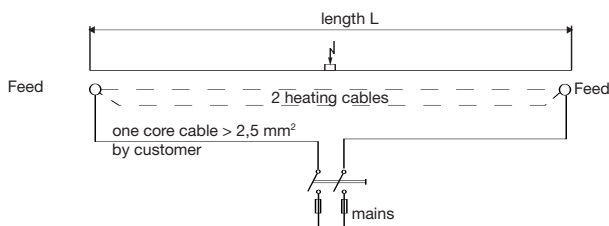

Switch gear assembly and temperature control unit as per customers inquiry. Fuses, cables etc. have to be provided by the customer.

Order for 60 m powerail (example)

- 1) 122 m heating cable type H 2,0 (2 x 60 m and 2 x 1 m additional)
 Voltage 400 V, two heating circles
 heating capacity as per above mentioned diagramm
 2 x 22 W/m at 60 m 2 x 22 W/m ~2640 W = 2,64 kW.
- 2) 1x Junction box left end
 1x Junction box right end
- 4) 4x sets of material for connection ends.

Contact section⁽¹⁾

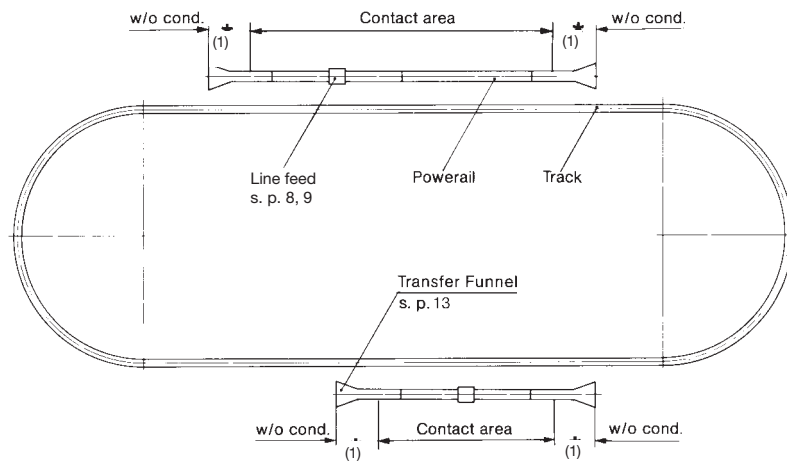

Turntable

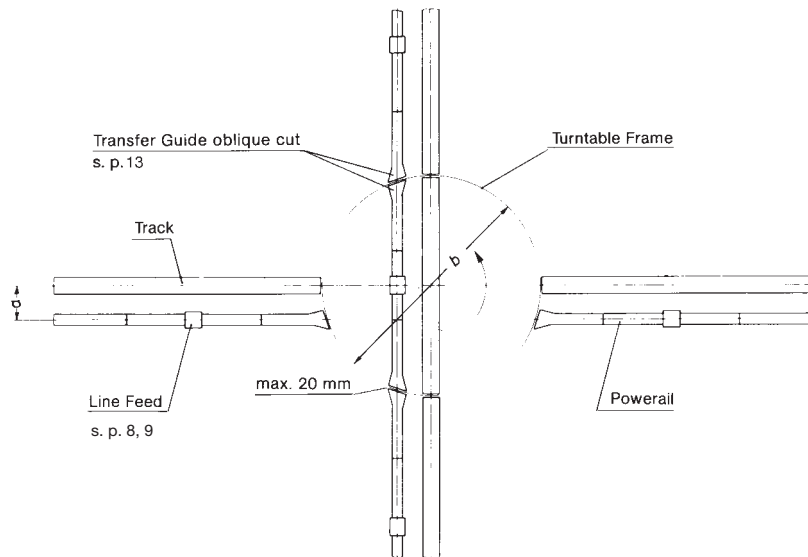

Sliding switch

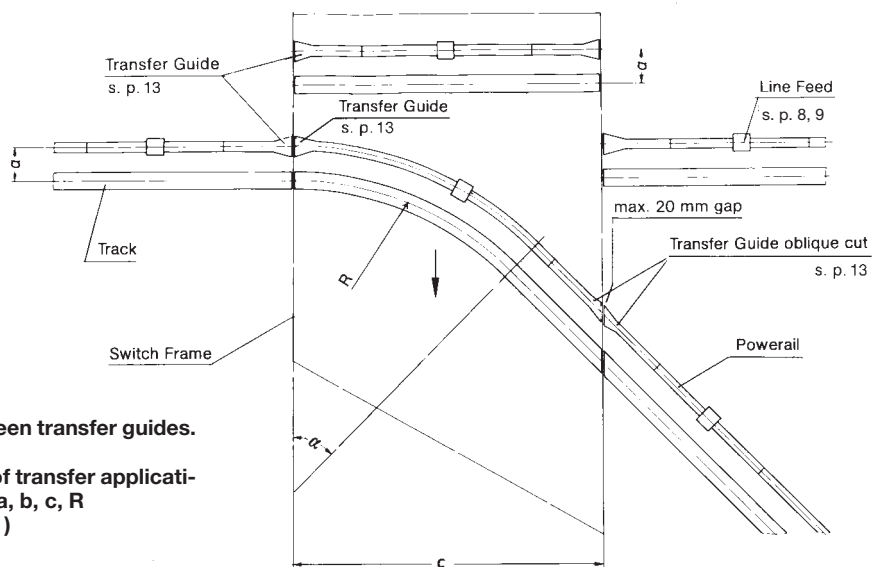

Max. 20 mm air gap between transfer guides.

Please submit drawings of transfer applications. Specify dimensions a , b , c , R and angle α ($\alpha = \text{max. } 50^\circ$)

⁽¹⁾ Contact sections must not be activated before collectors are fully engaged. Flexible tow arms (see page 18) for collectors are essential for contact sections.

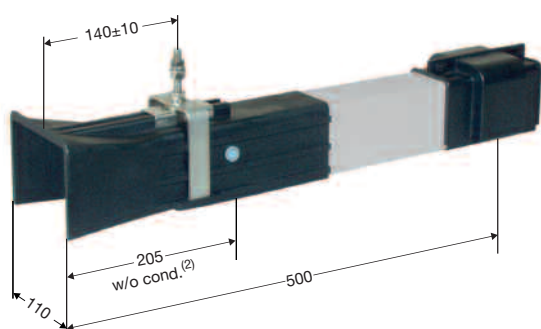

Offset: ± 15 mm horizontal
+ 10 mm vertical

Max. speed for transfer 60 m/min.

Transfer funnel

Powerail should not be activated before the collectors carbons have complete contact with the conductors.

Type ⁽¹⁾	weight kg	Order-No.	
		left version	right version
KET 4/ 40-125...HS	1,612	600 285	600 279
KET 4/160...HS	1,724	600 286	600 280
KET 4/200...HS	1,943	600 305	600 303
KET 5/ 40-125...HS	1,720	600 288	600 282
KET 5/160...HS	1,858	600 289	600 283
KET 5/200...HS	2,128	600 306	600 304
KET 4/ 40...SS	1,612	600 287	600 281
KET 5/ 40...SS	1,720	600 290	600 284

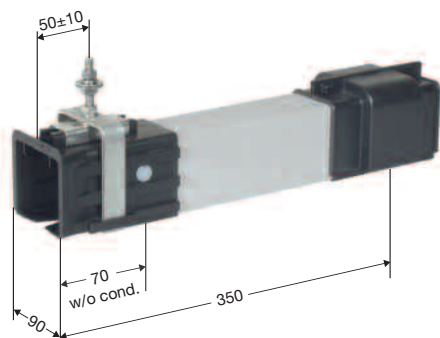

Offset: ± 8 mm horizontal
+ 3 mm vertical

Max. speed for transfer 80 m/min.

Transfer guides, straight

Type ⁽¹⁾	weight kg	Order-No.	
		left version	right version
KÜ 4/ 40-125...HS	1,348	600 261	600 255
KÜ 4/160...HS	1,448	600 262	600 256
KÜ 4/200...HS	1,640	600 309	600 307
KÜ 5/ 40-125...HS	1,500	600 264	600 258
KÜ 5/160...HS	1,625	600 265	600 259
KÜ 5/200...HS	1,865	600 310	600 308
KÜ 4/ 40...SS	1,348	600 263	600 257
KÜ 5/ 40...SS	1,500	600 266	600 260

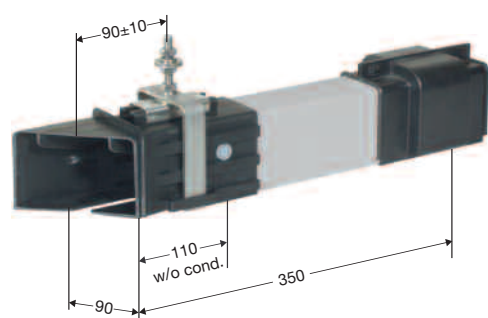

Offset: ± 8 mm horizontal
+ 3 mm vertical

Measurements (oblique) and angle
to be specified by customer

Max. speed for crossover 80 m/min.

Hinds for dimensioning the left-and right hand
version refer to page 4 and 5.

Transfer guides, oblique

Type ⁽¹⁾	weight kg	Order-No..	
		left version	right version
KÜS 4/ 40-125...HS	1,312	600 273	600 267
KÜS 4/160...HS	1,396	600 274	600 268
KÜS 4/200...HS	1,560	600 317	600 315
KÜS 5/ 40-125...HS	1,450	600 276	600 270
KÜS 5/160...HS	1,555	600 277	600 271
KÜS 5/200...HS	1,760	600 318	600 316
KÜS 4/ 40...SS	1,312	600 275	600 269
KÜD 5/ 40...SS	1,450	600 278	600 272

⁽¹⁾ Add types e.g. KET 4/40-125...HS
Left hand version KET 4/40-125 \perp HS Order-No. 600 285

⁽²⁾ corresponding to the center of collector



REMOVING SECTIONS • CONDUCTOR DEAD SECTIONS

KBHF
KBHS

Removing section

with special bolted joints for KBHF and KBHS on both ends.

Assembly and disassembly of the collector is possible at the end of the track as well as at the removing section.

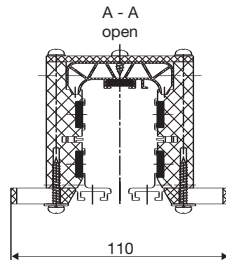
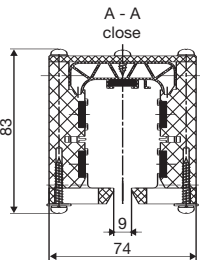
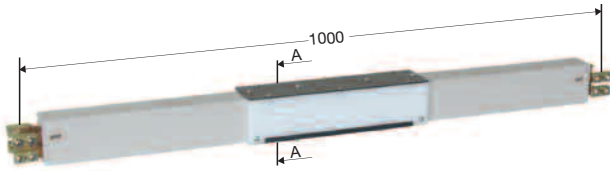

By opening and closing the sliders at the bottom of the powerail housing the collector can be mounted and demounted easily.

Before opening disconnect mains.

The removing section does not disconnect the powerail electrically.

For single collectors

Type	weight kg	Order No.
KAT 4/40-125 HS	3,450	600 165
KAT 4/160 HS	3,802	600 166
KAT 4/200 HS	4,494	600 327
KAT 5/40-125 HS	3,781	600 167
KAT 5/160 HS	4,133	600 168
KAT 5/200 HS	4,825	600 328
KAT 4/ 40 SS	3,450	600 169
KAT 5/ 40 SS	3,781	600 170

For double collectors

Type	weight kg	Order No.
KATD 4/40-125 HS	4,044	600 175
KATD 4/160 HS	4,396	600 176
KATD 4/200 HS	5,088	600 329
KATD 5/40-125 HS	4,375	600 177
KATD 5/160 HS	4,727	600 178
KATD 5/200 HS	5,419	600 330
KATD 4/ 40 SS	4,044	600 179
KATD 5/ 40 SS	4,375	600 180

Conductor dead section

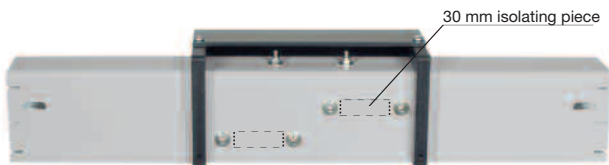

Picture shows a conductor dead section.

Please advise us which conductors should be disconnected (see Page 5). The dead section comes factory assembled.

Type	Order No.	Type	Order No.
KTL 1	600 298	KTI 1	600 293
KTL 2	600 299	KTI 2	600 294
KTL 3	600 300	KTI 3	600 295
KTL 4	600 301	KTI 4	600 296
KTL 5	600 302	KTI 5	600 297

ANTI - CONDENSATION SECTIONS • EXPANSION SECTION

included 1 m section



KBHF
KBHS

Anti-Condensation Sections

with special bolted joints for KBHF and KBHS at both ends.

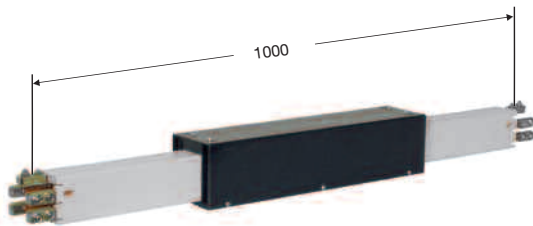

Application of Anti-Condensation Section

The anti-condensation section will be used where Powerails are passing from indoor to outdoor, preventing condensation of the outside mounted Powerail. The warm air from indoors can escape through the anti condensation section.

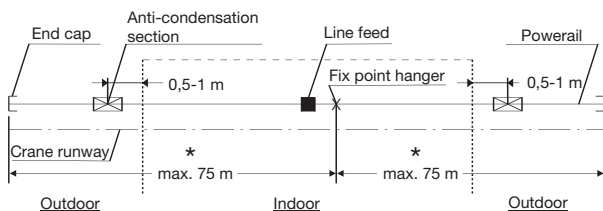

Type	weight kg	Order-No.
KBT 4/40-125 HS	3,858	600 185
KBT 4/160 HS	4,210	600 186
KBT 4/200 HS	4,902	600 319
KBT 5/40-125 HS	4,180	600 188
KBT 5/160 HS	4,532	600 189
KBT 5/200 HS	5,224	600 320
KBT 4/ 40 SS	3,858	600 187
KBT 5/ 40 SS	4,180	600 190

The anti-condensation section does not interrupt the Powerail electrically.

Installation

The anti-condensation section is to be placed directly (0,5 m - 1 m max.) at the transfer point from indoor to outdoor. See sketch.

* For longer runs use Expansion section.

Expansion Section

with special bolted joints for Powerail KBHF and KBHS (identical) including 1 m section.

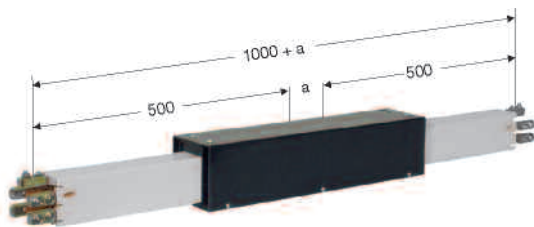

The Expansion sections are required to compensate the different expansions between copper conductors and steel- or concrete structures, in varying temperatures without interrupting electrical power.

Expansion joints are used when the Powerail length between feeds, curves, switches or other fix points is exceeding 20 m.

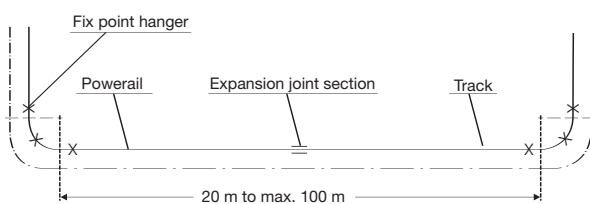
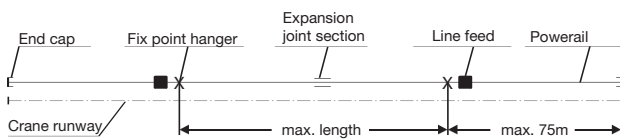

Type	weight kg	Order-No.
KD 4/ 40-125 HS	4,400	600 135
KD 4/160 HS	4,752	600 136
KD 4/200 HS	5,444	600 325
KD 5/ 40-125 HS	4,895	600 138
KD 5/160 HS	5,247	600 139
KD 5/200 HS	5,939	600 326
KD 4/ 40 SS	4,400	600 137
KD 5/ 40 SS	4,895	600 140

Max. length during differences in temperature:

Δt 90 °C (-30 °C to +60 °C) install one expansion joint per 100 m. An additional expansion joint every 100 m.

Additional feeds or current collectors are not required as the expansion-sections do not interrupt electrical power.

Assembly

The gap dimension „a“ is 75 mm and is valid for an ambient temperature of -10 °C to +35 °C during installation.



COLLECTORS

Collector KSW

max. speed 150 m/min.
Also for powerails with sealing strip up to 100 m/ min.



Connecting cables:

for 25 A with 2,5 mm²/core
for 40 A with 4,0 mm²/core
for 60 A with 6,0 mm²/core

1 m long, longer cables on request.

Cleaning collector on request.

Order example for a 2 m long cable
Order-No. 600 096-2
for collector **KSW 4/40-2 HS**

Type	Power rating at 60% DF A	No. of conductors	ca. ø of connecting-cables in mm	Travel speed in m/min.	weight kg	Order No.
KSW 4/25-1 HS	25	4	12,5	150	0,552	600 095
KSW 4/40-1 HS	40	4	14,5	150	0,656	600 096
KSW 4/60-1 HS	60 ⁽¹⁾	4	17,0	150	0,797	600 066
KSW 5/25-1 HS	25	5	13,5	150	0,634	600 098
KSW 5/40-1 HS	40	5	16,0	150	0,771	600 099
KSW 5/60-1 HS	60 ⁽¹⁾	5	19,5	150	0,945	600 413
KSW 4/25-1 ST	25	4	11,0	150	0,472	600 097
KSW 5/25-1 ST	25	5	12,0	150	0,534	600 100

Collector KSWs

max. velocity 250 m/min.
Also for powerails with sealing strip up to 100 m/ min.



Connecting cable:

for 25 A with 2,5 mm²/core
for 40 A with 4,0 mm²/core
for 60 A with 6,0 mm²/core

1 m long, longer cables on request.

Cleaning collector on request.

Order example for a 2 m long cable
Order-No. 600 149-2
for collector **KSWs 5/40-2 HS**

Type	Power rating at 60% DF A	No. of conductors	ca. ø of connecting-cables in mm	Travel speed in m/min.	weight kg	Order No.
KSWs 4/25-1 HS	25	4	12,5	250	0,664	600 145
KSWs 4/40-1 HS	40	4	14,5	250	0,768	600 146
KSWs 4/60-1 HS	60 ⁽¹⁾	4	17,0	250	0,942	600 416
KSWs 5/25-1 HS	25	5	13,5	250	0,724	600 148
KSWs 5/40-1 HS	40	5	16,0	250	0,861	600 149
KSWs 5/60-1 HS	60 ⁽¹⁾	5	19,0	250	1,035	600 417
KSWs 4/25-1 ST	25	4	11,0	250	0,584	600 047
KSWs 5/25-1 ST	25	5	12,0	250	0,624	600 150

Double collectors

The double collectors are supplied as an assembly kit consisting of:
2 collectors (KSW) and a connecting bar with mounting material.

For the collector KSWs there are no double collectors available 2 single collectors must be used instead.

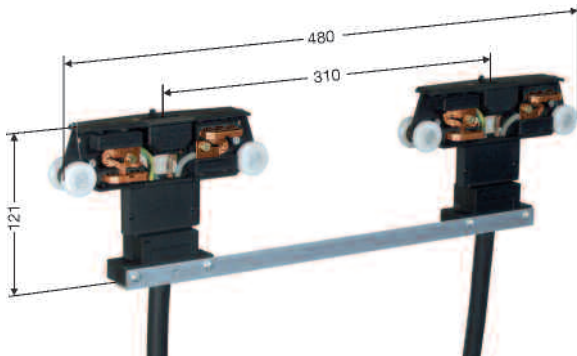

Connecting cable:

for 50 A with (2x) 2,5 mm²/core
for 80 A with (2x) 4,0 mm²/core
for 120 A with (2x) 6,0 mm²/core

1 m long, longer cables on request.

Order example for 2 m long cables
Order-No. 600 119-2
for collector **DKSW 5/80-2 HS**

Type	Power rating at 60% DF A	No of-conductors	ca. ø of connecting-cables in mm	Travel speed in m/min.	weight kg	Order-No.
DKSW 4/ 50-1 HS	50	4	12,5	150	1,170	600 115
DKSW 4/ 80-1 HS	80	4	14,5	150	1,378	600 116
DKSW 4/120-1 HS	120 ⁽¹⁾	4	17,0	150	1,660	600 414
DKSW 5/ 50-1 HS	50	5	13,5	150	1,334	600 118
DKSW 5/ 80-1 HS	80	5	16,0	150	1,608	600 119
DKSW 5/120-1 HS	120 ⁽¹⁾	5	19,0	150	1,956	600 415
DKSW 4/ 50-1 ST	50	4	11,0	150	1,010	600 117
DKSW 5/ 50-1 ST	50	5	12,0	150	1,134	600 120

Tow arm with tube or square hollow profile

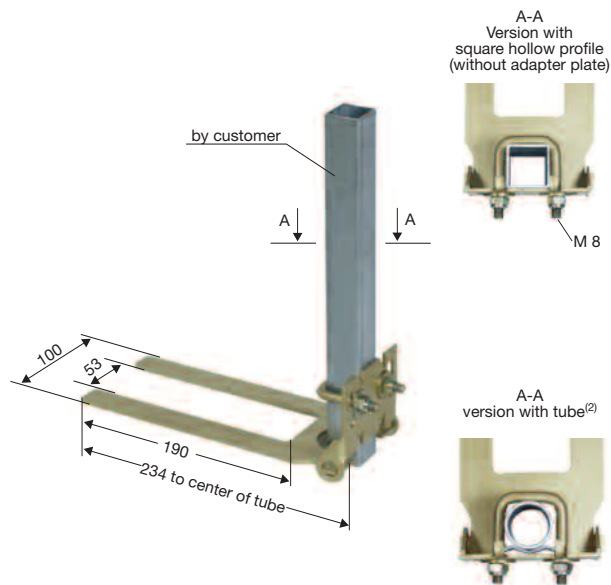

Type	weight kg	Order-No.
MGU	0,550	600 334
MGU/K	0,550	600 336

Tow arm for plane surface

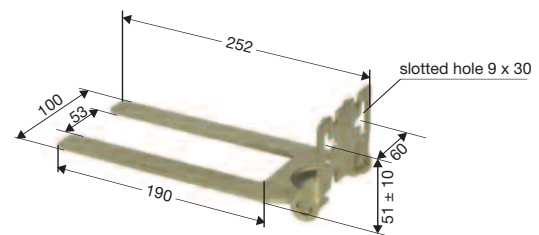

Type	weight kg	Order-No.
MGF	0,510	600 335
MGF/K	0,510	600 337

⁽¹⁾ At 40% ED

⁽²⁾ For assembly use enclosed adapter plate.



FLEXIBLE TOW ARM • INSTALLATION

KBHF
KBHS

Flexible tow arm

flexible support type for single collector for installations with transfer funnels type KET (see page 13) Measurements for installation see below

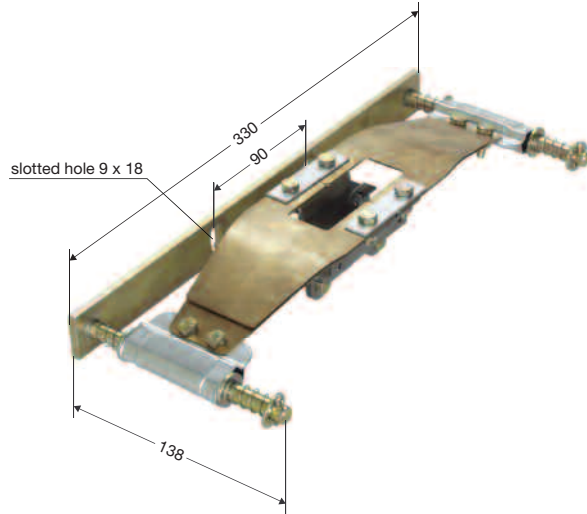

Type	weight kg	Order No.
KFMH	1,200	600 333

Flexible tow arm

Arrangement of type KFMH with collector type KSW

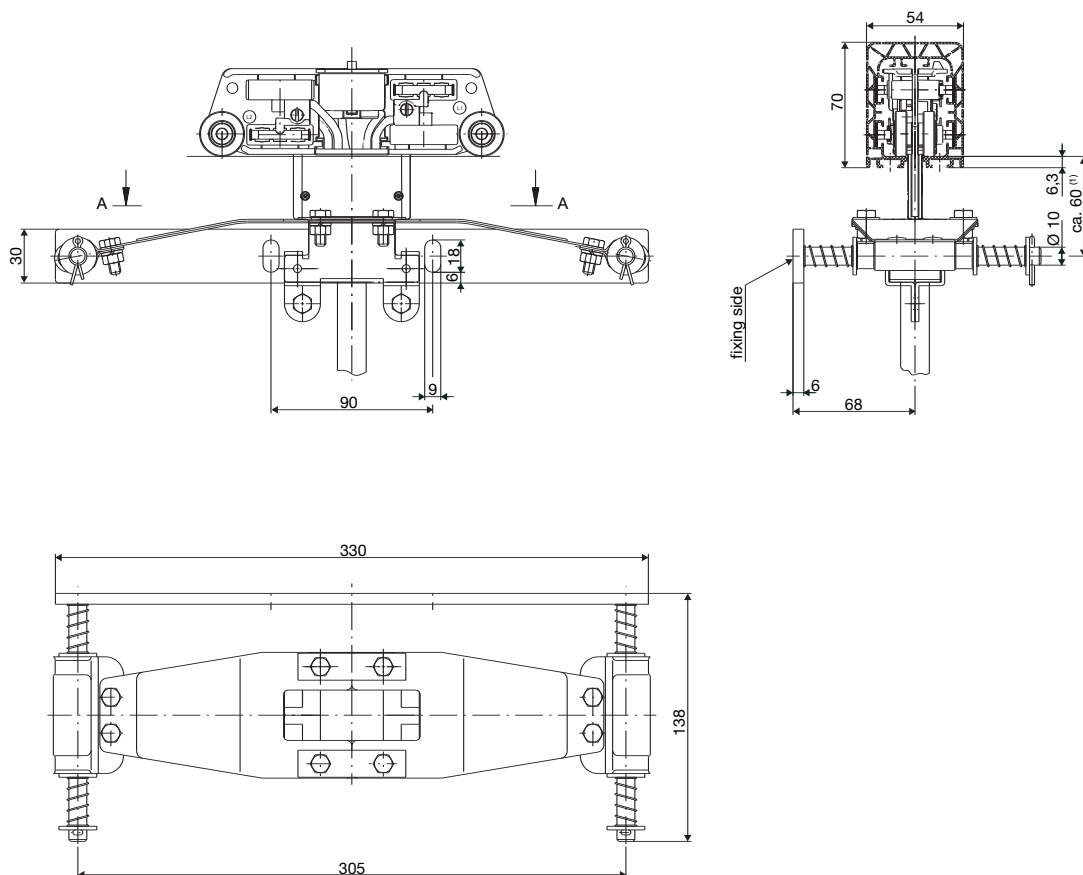



Examples for ordering

Installation length of 64 m KBH... (configuration see page 4)

Quantity	Article	KBHF 4/63 HS with end feed		KBHF 5/100 HS with line feed		KBHS 5/200 HS with line feed including 1 m section	
		Type	Order-No.	Type	Order-No.	Type	Order-No.
16	Powerail, 4 m long	KBHF 4/63-4 HS	600 014	KBHF 5/100-4 HS	600 124	-	-
15	Powerail, 4 m long	-	-	-	-	KBHS 5/200-4HS	600 184
1	Powerail, 3 m long	-	-	-	-	KBHS 5/200-3HS	600 183
1	End feed	KKE 4/40-63 HS	600 010	-	-	-	-
1	Line feed	-	-	KSE 5/100 HS	600 039	-	-
1	Line feed 1 m long	-	-	-	-	KELS 5/160 HS	600 079
1	End cap	KE	600 008	-	-	-	-
2	End cap	-	-	KE	600 008	KE	600 008
15	Joint cap	KVM	600 005	-	-	-	-
14	Joint cap	-	-	KVM	600 005	-	-
16	Joint cap	-	-	-	-	KVM	600 005
1	Fix point hanger	KFA	600 007	KFA	600 007	KFA	600 007
32	Sliding hanger	KGA	600 000	KGA	600 000	KGA	600 000
1	Collector	KSW 4/40-1 HS	600 096	KSW 5/40-1 HS	600 099	KSW 5/40-1 HS	600 099
1	Tow arm	MGU	600 334	MGU	600 334	MGU	600 334

Spare part list

Powerail	KBHF	KBHS
	Order-No.	Order-No.
Joint cap (pair)	600 005	600 005
Spring loaded connector 40 - 100 A	600 087	-
Bolted joints 40 - 160 A	-	234 685
Bolted joints 200 A	-	600 110
Neoprene sealing strip, in pairs (max. length 50 m each)	235 794	235 794
Coupling for sealing strip, in pairs (for lengths < 50 m each)	258 300	258 300
Fixing clamp for sealing strip (1 per end)	600 354	600 354
Mounting glider for sealing strip	600 109	600 109
Feed terminal for end feed (40/63 A)	600 006	600 006
Feed terminal for line feed (lateral)	600 017	600 017
Feed terminal for line feed (on top, 5th conductor)	600 016	600 016

Spare part list

Collector	KSW/DKSW	KSWS
	Order-No.	Order-No.
Carbon brush phase (lateral)	600 088	600 088
Carbon brush 5th conductor (top)	600 089	600 089
Carbon brush ground (lateral PE)	600 090	600 090
Carbon pressure spring (standard), suitable for all carbon brushes	600 338	600 338
Connecting bar for double collector DKSW	600 105	-
Assembly kit (to convert KSW → KSWS)	-	600 106

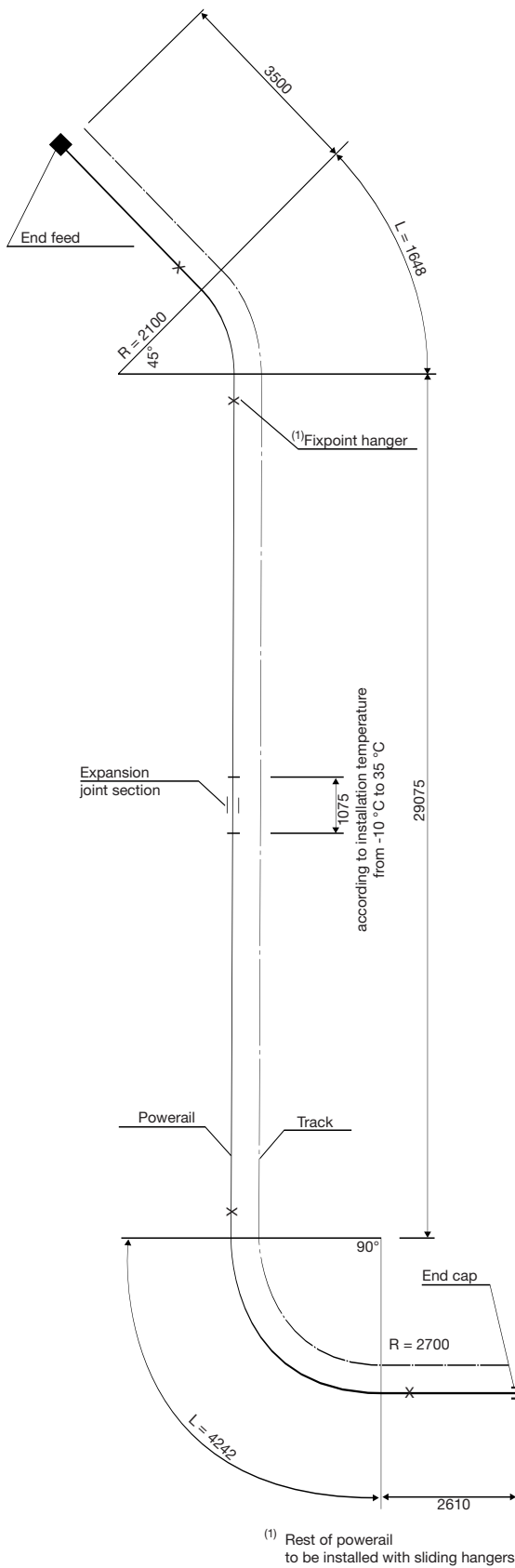

Installations with curves as per customer drawing

41,075 m powerail KBHF 4/63 consisting of:

Qty	Description	Type	Order No.
7	Powerail, 4 m long	KBHF 4/63-4 HS	600 014
1	Powerail, 4 m long for 1 x 3500 mm short length	KBHF 4/63-4 HS	600 014
2	Powerail, 3 m long for 1 x 2610 mm u. 1 x 2500 mm short length	KBHF 4/63-3 HS	600 013
1	Powerail, 2 m long for horizontal curve 45°, R = 2100 mm, L = 1648 mm, SA	KBHF 4/63-2 HS	600 012
2	Powerail., 3 m long for horizontal curve 2 x 45°, R = 2700 mm, L = 2121 mm, SI	KBHF 4/63-3 HS	600 013
3	Surcharge for bending (horizontal)		600 068
1	End feed	KKE 4/40-63 HS	600 010
1	Expansion section	KD 4/40-125 HS	600 135
11	Joint caps	KVM	600 005
4	Fixpoint hangers	KFA	600 007
24	Sliding hangers	KGA	600 000
1	End cap	KE	600 008
1	Collector	KSW 4/40-1 HS	600 096
1	Tow arm	MGF	600 335

41,075 m powerail KBHS 5/63 consisting of:

Qty	Description	Type	Order No.
8	Powerail, 4 m long	KBHS 5/63-4 HS	600 114
1	Powerail, 4 m long for 1 x 3500 mm short length	KBHS 5/63-4 HS	600 114
2	Powerail, 3 m long for 1 x 2610 mm u. 1 x 2500 mm short lengths	KBHS 5/63-3 HS	600 113
1	Powerail, 2 m for horizontal curve 45°, R = 2100 mm, L = 1648 mm, SA	KBHS 5/63-2 HS	600 112
2	Powerail, 3 m for horizontal curve 2 x 45°, R = 2700 mm, L = 2121 mm, SI	KBHS 5/63-3 HS	600 113
3	Surcharge for bending (horizontal)		600 068
1	End feed	KKE 5/40-63 HS	600 107
1	Expansion section	KD 5/40-125 HS	600 138
11	Joint caps	KVM	600 005
4	Fixpoint hangers	KFA	600 007
24	Sliding hangers	KGA	600 000
1	End cap	KE	600 008
1	Collector	KSW 5/40-1 HS	600 099
1	Tow arm	MGF	600 335



Company: _____ Date: _____

 Tel: _____ Fax: _____
 E-Mail: _____ Internet: (URL) _____

1. Number of powerail installations: _____
2. Type of equipment to be powered: _____
3. Operating voltage: _____ Volts, Phases: _____, Frequency: _____ Hz
 Three phase voltage: AC voltage: DC voltage:
4. Track length: _____
5. Number of powerails: _____ (neutral: _____ control rails: _____ ground rail: _____)
6. Mounted position of powerail:
 - Powerail pendant, collector cable facing to the bottom
 - Support distance _____ m (max. 2 m)
 - Other: _____
7. Number of consumers per system: _____
8. Indoor: Outdoor:
9. Other operating conditions (humidity, dust, chemical influence etc.)

10. Ambient temperature: _____ °C min. _____ °C max.
11. Position and number of feeding points and isolating sections⁽¹⁾: _____
12. Position and number of isolating sections (e.g. for maintenance): _____
13. Brackets required: yes no c/c distance beam /Powerail
14. How are the rails laid out? (Please provide sketch): _____
15. Travel speed: _____
16. Power consumption of the individual consumer loads:
 (Please consult table on reverse side) _____
17. Max. Voltage drop from the powerail feed point to the consumer considering starting current:
 3% or _____ % referring to nominal voltage

Remarks: _____

⁽¹⁾ For curved tracks, powerail with isolating sections etc., we require sketches to enable us to prepare a quotation. ptol



QUESTIONNAIRE

Paul Vahle GmbH & Co. KG
 D 59172 Kamen
 Telefax 0 23 07 / 70 44 44
 E-Mail: export@vahle.de
 Internet: www.vahle.de

Date: _____

Motor data	Crane 1					Crane 2							
	Power kW	Nominal current		Starting current		Type of Motos ⁽¹⁾	Power kW	Nominal current		Starting current		Type of Motos ⁽¹⁾	
		A	cos φ_N	% ED	A	cos φ_A		A	cos φ_N	% ED	A	cos φ_A	
Hoist motors													
Auxiliary hoist													
Long travel													
Cross travel													

Motor data	Crane 3					Crane 4							
	Power kW	Nominal current		Starting current		Type of Motos ⁽¹⁾	Power kW	Nominal current		Starting current		Type of Motos ⁽¹⁾	
		A	cos φ_N	% ED	A	cos φ_A		A	cos φ_N	% ED	A	cos φ_A	
Hoist motors													
Auxiliary hoist													
Long travel													
Cross travel													

Mark with * those motors which can run simultaneously.
 Mark with Δ those motors which can start up simultaneously.

⁽¹⁾Use: K for squirrel cage motor
 S for slipring motor
 F for frequency controlled motor

Further remarks: _____

Signature: _____



Crane installations at company Rheinmetall Landsysteme (Kiel)



Products and Service

Catalog no.

Powerails	1 a
Battery Charging Systems	1 b
Insulated Powerails U 10	2 a
Insulated Powerails U 20 - U 30 - U 40	2 b
Insulated Powerails U 15 - U 25 - U 35	2 c
Aluminum Enclosed Conductor Systems LSV - LSVG	3 a
Powerail Enclosed Conductor Systems KBSL - KSL - KSLT	4 a
Powerail Enclosed Conductor Systems VKS - VKL	4 b
Powerail Enclosed Conductor Systems MKLD - MKLF - MKLS	4 c
Powerail Enclosed Conductor Systems VKS 10	4 d
Powerail Enclosed Conductor Systems KBH	4 e
Heavy Enclosed Conductor Systems	5
Trolley Wire and Accessories	6
Cable Tenders	7
Cable Carriers for □ tracks	8 a
Cable Carriers for Flatarm Cables on I beams	8 bF
Cable Carriers for Round Cables on I beams	8 bR
Cable Carriers and Accessories for ◇ tracks	8 c
Conductor Cables and Fittings	8 L
Spring Operated Cable Reels	9 a
VAHLE POWERCOM® Digital Transmission Systems	9 c
CPS® Contactless Power Supply	9 d
SMG - Slotted Microwave Guide	9 e
Position Encoding Systems	9 f
Motor Powered Cable Reels	10
Installations/Commissioning	
Spare Parts/Maintenance Service	

